

Arc Guard System TVOC

Catalogue 1SFC 266006-en, Edition 3 November 2003
Supersedes Catalogue 1SFC 266006-en, Edition 2
November 2000



ABB

Arc Guard System TVOC

System units

The two units of the Arc Guard System TVOC are used as below:

1. Arc Monitor with detectors

Operates alone.

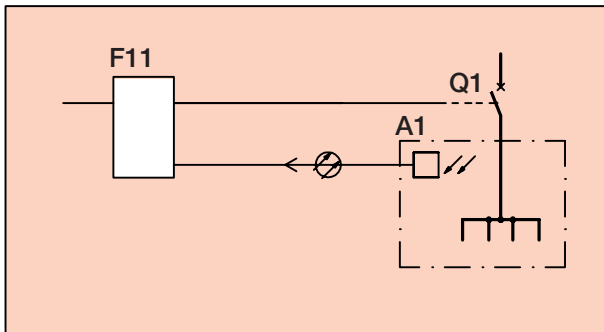

2. Current Sensing Unit and Arc Monitor

Operates only together.

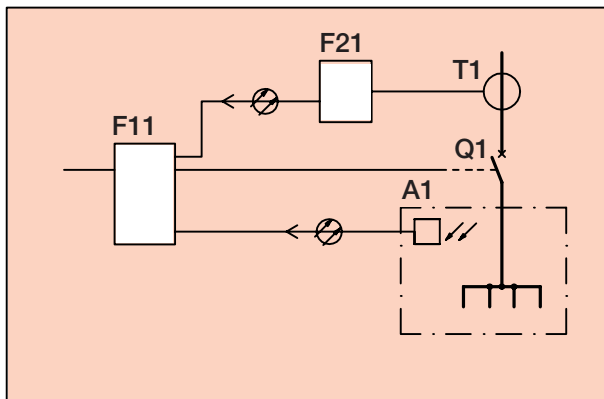

| | |
|-----|----------------------|
| A1 | Switchgear |
| F11 | Arc Monitor |
| F21 | Current Sensing Unit |
| T1 | Current transformer |
| Q1 | Circuit-breaker |

Approvals



Dimensions in mm. The design, data and dimensions are subject to modification without notice.



Contents

| | |
|----------------------------|----|
| Ordering particulars | 4 |
| Description | 6 |
| Technical data | 8 |
| Dimensions | 9 |
| Diagrams | 10 |
| Application diagrams | 11 |



Arc Guard System TVOC

Ordering particulars



| Order Code | Weight kg |
|------------|--------------|
|------------|--------------|

Arc Monitor

For power supply voltage

60–220 V, DC or

60–240 V, 50–60 Hz

24–48 V, DC

1SFA 663 001 R1001

1.68

1SFA 663 001 R1002

1.68

Arc Monitor - simplified version

For power supply voltage

60–220 V, DC or

60–240 V, 50–60 Hz

24–48 V, DC

1SFA 663 001 R1003

1.68

1SFA 663 001 R1004

1.68

New

Detectors ¹⁾

with optical cable of **plastic fibre**

Cable length

1 m

1SFA 663 003 R1010

0.02

2 m

1SFA 663 003 R1020

0.02

4 m

1SFA 663 003 R1040

0.04

6 m

1SFA 663 003 R1060

0.06

8 m

1SFA 663 003 R1080

0.08

10 m

1SFA 663 003 R1100

0.10

15 m

1SFA 663 003 R1150

0.15

20 m

1SFA 663 003 R1200

0.20

25 m

1SFA 663 003 R1250

0.20

30 m

1SFA 663 003 R1300

0.30

Other lengths

On request

Current Sensing Unit

The unit can be connected

to either of these supply voltages:

24, 48, 60, 110, 125, 220 V DC

or 110...127 or 230 V AC.

1SFA 663 002-A

1.5

Optical cable of plastic fibre ¹⁾

For connection between units:

- Current Sensing Unit to Arc Monitor
 - Arc Monitor to Arc Monitor
 - Current Sensing Unit to Current Sensing Unit
- The cables are provided with plug-in connectors.

Cable length

0.5 m

1SFA 663 004 R1005

0.01

1 m

1SFA 663 004 R1010

0.01

2 m

1SFA 663 004 R1020

0.02

4 m

1SFA 663 004 R1040

0.04

6 m

1SFA 663 004 R1060

0.06

8 m

1SFA 663 004 R1080

0.08

10 m

1SFA 663 004 R1100

0.10

15 m

1SFA 663 004 R1150

0.15

20 m

1SFA 663 004 R1200

0.20

25 m

1SFA 663 004 R1250

0.25

30 m

1SFA 663 004 R1300

0.30

¹⁾ Also suitable for Arc Monitor 1SFA 663 001-A...-B, SK 663 121-A...-G and SK 663 122-A...-G.

Description page 6
Technical data page 8
Dimensions page 9
Diagrams page 10

Arc Guard System TVOC

Ordering particulars

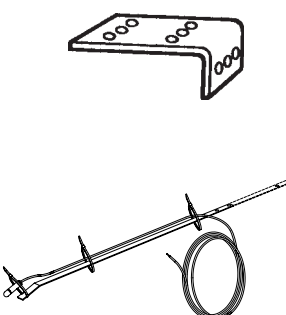

This equipment is protected by Arc Monitor type TVOC
 Avoid photo flashes and intense light!

Detector No. Monitor No./Item

ABB Control

2640 1743-5

Description page 6
Technical data page 8
Dimensions page 9
Diagrams page 10

| Order Code | Weight kg |
|------------|--------------|
|------------|--------------|

Mounting bracket set

For mounting of detectors.
 Detectors are secured to the bracket by means of cable straps.

| | | |
|---|---------------------------|------|
| 1 set including 5 pcs of bracket and 10 pcs of cable strap | 1SFA 663 006 R1010 | 0.25 |
|---|---------------------------|------|

Mounting kit

| | | |
|-----------------|---------------------------|------|
| 600 mm | 1SFA 663 006 R1001 | 0.35 |
| 800 and 1000 mm | 1SFA 663 006 R1002 | 0.60 |

Installation and Maintenance Instruction

| | |
|--------------------------------------|---------------------------|
| English | 1SFA 663 007 R1001 |
| Swedish | 1SFA 663 007 R1002 |
| German | 1SFA 663 007 R1003 |
| Spanish | 1SFA 663 007 R1004 |
| Finnish | 1SFA 663 007 R1005 |
| English (for the simplified version) | 1SFA 663 007 R1011 |
| Swedish (for the simplified version) | 1SFA 663 007 R1012 |

Information label

Label to apply to the front of the switchgear cubicle. Text: This equipment is protected by Arc Monitor type TVOC

| | | |
|------------------------|---------------------------|------|
| 1 set including 10 pcs | 1SFA 663 005 R1001 | 0.02 |
|------------------------|---------------------------|------|

Flush mounting set

Consisting of mounting bracket, gasket and screws.

| | |
|---------------------------|------|
| 1SFA 663 006 R1015 | 0.53 |
|---------------------------|------|

Drilling plan

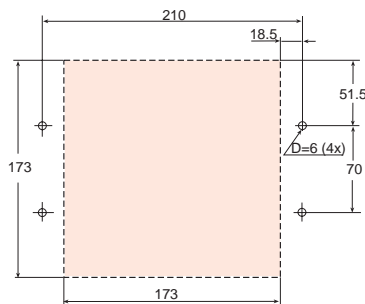

Arc Guard System TVOC

Description

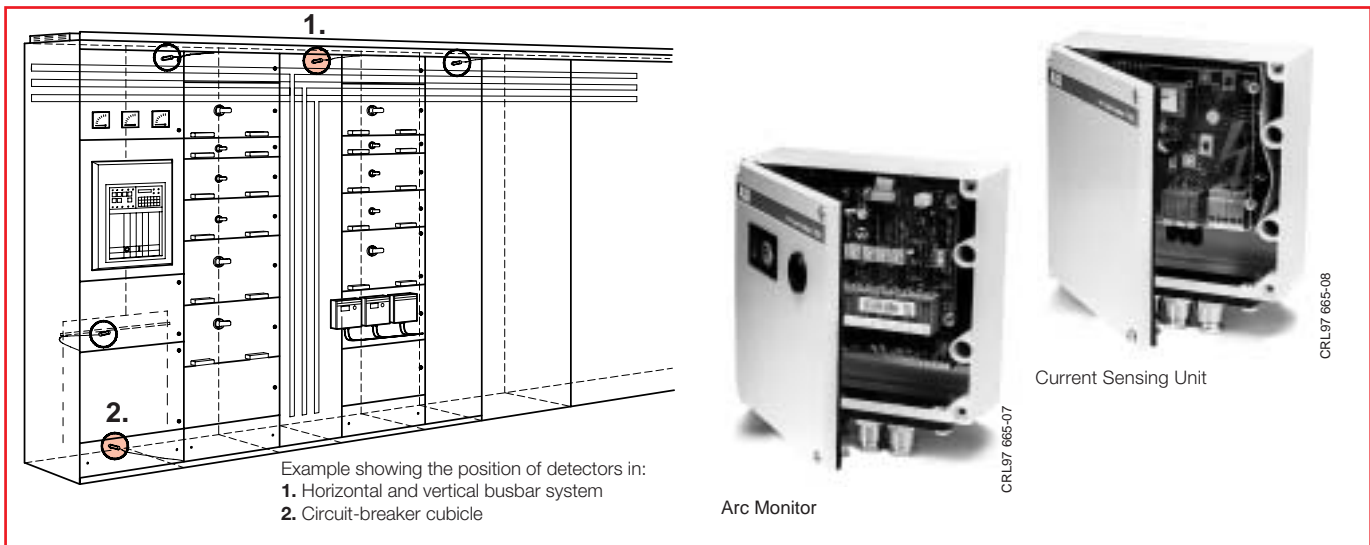

Arc faults

Most short circuit faults in LV and MV switchgears are accompanied by an electric arc. An arc fault always leads to considerable damage to equipment and personnel unless it is distinguished very fast. The fault should be disconnected as fast as possible and in less than 0.1 s to avoid serious damages and give involved person a fair chance to survive the accident without severe damages. This is a demand found in the electrical safety rules in all CE countries, ref. IEC364-4-42.

The Arc Guard System TVOC is an aid to quickly detect an arc fault and trip the incoming circuit-breaker. The main advantage with the Arc Guard System is that it can trip instantaneously, i.e. override other tripping functions.

Function

The Arc Guard System TVOC is used for high-speed tripping of the main circuit-breaker in the event of an arc fault.

Arc Monitor with detectors

The unit reacts to short-circuit arcs and immediately transmits a tripping signal.

- A maximum of nine detectors can be connected to each Arc Monitor unit. (Max. four detectors for the simplified version).
- **Normally only one detector is required in each compartment**
- The Arc Monitor can be located anywhere in the switchgear.
- For practical reasons, the length of the optical fibre cables should be kept to a minimum.

Should an arc occur, the detector concerned transmits the light to the Arc Monitor and a solid state contact in it operates within a millisecond. This contact is connected in series with the shunt release of the circuit-breaker. Even if the over-current release of the circuit-breaker is delayed to provide selectivity, this does not influence the operation of the Arc Monitor.

Current Sensing Unit

In addition to the light produced by arcs, the Arc Monitor is also sensitive to other sources of intense light such as photo flashes, sunlight directly on the detector, intense lamp light close to a detector or normal arc light from such large items as circuit-breakers. By combining the Arc Monitor with a Current Sensing Unit, a current logic condition is introduced that prevents circuit-breaker tripping by none relevante light sources.

EMC feature

The switchgear and controlgear equipment in which the Arc Guard System is intended to be placed generally represents a severe environment in terms of electromagnetic interference. High currents in busbars and cables, switching of inductive loads, arcs from switching equipment etc. generate electromagnetic fields of considerable strength.

Electrical wires act as antennas and pick up electrical interference voltage. By using optical fibres the Arc Monitor installation is not sensitive to electromagnetic interference.

The basic EMC publications IEC 1000 define different electrical environment classes and corresponding test levels. A switchgear is generally regarded as a more severe electrical environment than a typical industrial electrical installation. The Arc Guard System TVOC is tested acc. to the test level for severe industrial environment or switchgears with mixed signal and power cables.

The Arc Guard System is tested according to following standards:

- IEC 1000-4-2, level 3
- IEC 1000-4-3, level 3
- IEC 1000-4-4, level 4 and corresponding part of SS 436 15 03, PL4
- IEC 1000-4-5, level 4/3
- IEC 1000-4-6, level 3
- IEC 1000-4-11
- IEC 1000-4-12, level 4/3

The Arc Guard System fulfils the requirements for CE-marking acc. to: The EMC-directive 89/336/EEC, tested according to EN 50081-1 and EN 50082-2. The Low Voltage Directive 73/23/EEC.

The Arc Guard System is UL-listed.

System security

The Arc Guard System is a product to ensure highest possible safety level and is expected to operate with absolute dependability.

The system is provided with testing functions and it should be checked at regular intervals.

The test procedure is described in the instruction manual.

Description of the Arc Guard System

The two units of the Arc Guard System TVOC, the Arc Monitor and the Current Sensing Unit are each built into a light-alloy enclosure provided with a hinged door.

Communication between the units and between Arc Monitors and detectors is via optical fibre cables.

The simplified version of the Arc Guard System is specially suited for substations.

Note: The simplified version of the Arc Guard System can not be used with the Current Sensing Unit.

Arc Guard System TVOC

Description

Combinations

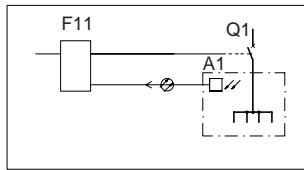

Arc Guard System with Arc Monitor

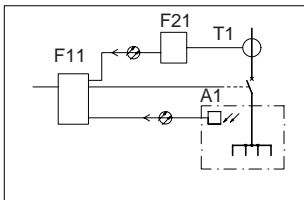

Arc Guard System with Arc Monitor and Current Sensing Unit

- A1 Switchgear
- F11 Arc Monitor
- F21 Current Sensing Unit
- T1 Current transformer
- Q1 Circuit-breaker

Arc Monitor

- Available for AC and DC supply.
- The two output stages are triacs triggered via a pulse transformer. In this way, the output stages are galvanically separated from each other and from other circuits.
- The Arc Monitor has two separate relay outputs. Each relay has one change-over contact function. Relay K1 is used for EXTERNAL TRIP indication and relay K2 is used for POWER ON indication.
- A switch is included for selection of automatic relay resetting (after approx. 200 ms) or manual resetting of relay K1.
- A digital display, visible through the window in the door, shows which detector has caused tripping. The display and relay are reset by the pushbutton in the door. The Arc Monitor can trip again even if it is not reset.
- Terminals for connection of power supply voltage, circuit-breaker trip circuits and signal circuits. Optical plug-in connectors are provided for the detectors and for the communication cables to other units. (Not for the simplified version)
- The power consumption of the unit is approx. 6 W. Energy is stored in the unit for operation up to 0.2 s if the supply voltage would fail, this is sufficient to activate the output even if voltage disappears in conjunction with a short circuit fault.

Current sensing unit

- For AC and DC
- Terminals for connection of external current transformers.
- The function of the current sensing unit is to block the tripping of the arc monitor at a load current below a certain adjustable value.
- The unit incorporates a selector switch and a potentiometer for testing purpose.
- Power consumption is approx. 11 W.
- Optical signal transmission
- If several Current Sensing Units are needed, they can be connected in series using optical cables.
- LEDs indicate when the load current exceeds approx. 70% and 100% of the set value.

Connection of current transformers

The unit is to be connected to current transformers with a rated secondary current of 1, 2 or 5 A.

Note that current transformers for relay protection are to prefer since these do not saturate as quickly as ordinary current transformers. The transformers selected should not saturate before at least 2 times the set over current level.

The current sensing unit can be either 1, 2 or 3-phase connected, however, three-phase is to prefer for safety reasons.

The burden of the unit is only 0,7 VA so current transformers for other purposes can often be used.

Detectors and Optical cables

General

The used optical plastic fibre cables are prefabricated and can not be cut or joint and they must be run in smooth curves during the installation. Both **Detector cables** and **Optical cables** are available in certain standard lengths, see the ordering table. Other lengths can be quoted on request. Maximum length, see ordering table. The plastic fibre is made of polymethylene acrylate (PMMA) with a jacket of PVC.

Detectors

Each detector consists of an optical cable and a lens that are calibrated together to get the same sensitivity independent of cable length. The detector has a plug-in connector that fits to the arc monitor. The lens collects light from all directions, with exception of a small shaded area behind the detector. See polar diagram below.

Practical experiments have shown that arc light reflected between metallic surfaces may be sufficient to cause tripping.

A maximum of nine detectors can be connected to Arc Monitor 1SFA 663 001 R1001 and 1SFA 663 001 R1002 . To the simplified version 1SFA 663 001 R1003 four detectors can be connected

If more detectors are required, several units can be connected in parallel.

Detection area

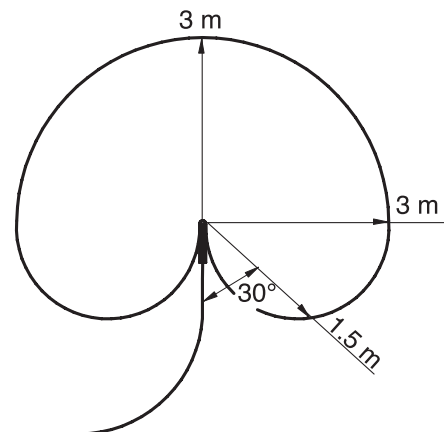

Polar diagram of detector in three dimensions

Tripping of several breakers

For tripping of several breakers an intermediate relay is often required. In order not to delay the tripping function a relay of fast acting type (4 ms) is recommended.

For DC trip circuits ABB's relay of type RXMS (Order Code. RK 216 263-...) is suitable. Where a greater load capacity is required this relay can be connected in parallel with a relay of type RXMH (Order Code RK 223 067-...).

In DC trip circuits it is necessary to add an external break contact in series to reset the triacs after tripping.

An impulse relay with an indication flag can be used to indicate a tripped Arc Monitor even after loss of auxiliary voltage. A suitable impulse relay of type E251, E252, E254, E255 or E256 can be chosen from our system ProM assortment.

Arc Guard System TVOC

Technical data

Arc Monitor

Solid state contacts (K3, K4)(triacs)disconnectible terminals

Largest load current:

| | |
|--------------|-------|
| Continuously | 0.7 A |
| For 200 ms | 30 A |

Smallest recommended load current

| | | |
|---|----|--------------------------|
| (temperature $\geq 25^\circ\text{C}$) | DC | 45 mA at stated polarity |
| | AC | 80 mA |
| (temperature $\geq -25^\circ\text{C}$) | DC | 80 mA at stated polarity |

Leakage current, I_r at 220 V, AC

| | |
|--------------------|--|
| | 8 mA |
| at DC | 0.5 mA |
| For other voltages | AC $I_r = U \times f \times 0,0006 \text{ (mA)}$ |

Peak withstand voltage 600 V

Load voltage Max. 250 V

Signal relay contacts (K1, K2) **1SFA 663 001....**

R1001, R1002 R1003, R1004

| | | |
|--|---------------|---------------|
| Thermal rated current, I_{th} | 5 A | 5A |
| Rated operational current, I_e | | |
| Utilisation category as per IEC 947-5-1: | | |
| AC-15 $U_e=250\text{ V}$ | 1.5 A | 1,5 A |
| DC-13 $U_e=48\text{ V}$ | 1.0 A | 1,0 A |
| 110 V | 0.3 A | 0,3 A |
| 220 V | 0.15 A | 0,15 A |
| Minimum switching load | 5 V DC, 10 mA | 5 V DC, 10 mA |

Optical inputs Quantity

| | | |
|--|---|---|
| For light detectors | 9 | 4 |
| From Current Sensing Unit or another Arc Monitor | 1 | - |

Optical outputs

| | | |
|------------------------|------------|---|
| To another Arc Monitor | 1 | - |
| To Breaker Fault Unit | 1 Not used | - |

Indications:

| | |
|-----------------------------|--|
| Operating voltage available | Decimal point on digital display lit up. Relay K2 energized. |
| Upon tripping | Digital display lit up. The digit shows which detector was active (1...9). Relay K1 energized. |

Control devices/settings:

External (on door)

Pushbutton

| | |
|--------------------|------------------|
| - Resetting button | Manual resetting |
|--------------------|------------------|

Internal (on p.c.b.)

Change-over switch

| | |
|--|--------|
| - Switching on and off of Current Sensing Unit | On/Off |
| - Manual resetting of signal relay | On/Off |

Trimming potentiometers

| | |
|-----------------------|------------------------------------|
| - Sensitivity setting | Normally not to be adjusted |
|-----------------------|------------------------------------|

Supply voltage:

| | |
|---------------------|--|
| Permitted variation | See ordering table +/- 20 % at DC +/- 10 % at AC |
| Internal fuse | 0.8 A delayed (5 x 20 mm) |
| Main fuse | max 10 A fast |

Power consumption 6 W

Permissible ambient temperature -25...+55 °C

Operating time:

| | |
|---|---|
| From detection to switched on triac outputs | approx. 1 ms (dependent on light intensity) |
| From detection to made relay contact | < 10 ms |
| Current condition from input to output | < 0.3 ms (with 1 m optical cable) |

(not for the simplified version)

Degree of protection IP 54

Start-up time for power on

| | |
|--|--|
| | $\leq 50\text{ ms}$ at 60V AC/DC |
| | $\leq 15\text{ ms}$ at 220-240 V AC/DC |
| | $\leq 50\text{ ms}$ at 24 V DC |
| | $\leq 15\text{ ms}$ at 48 V DC |

Approvals

See page 2

Current Sensing Unit

Rated current

Selectable, for connection of external current transformers with secondary rated current

1, 2 or 5 A

Load on the external current transformers

0.2 VA connected for 1 A
0.7 VA connected for 5 A

The Current Sensing Unit withstands a maximum of:

Continuously 1 x rated current
For 1 s 15 x rated current

Optical outputs:

To Arc Monitor/Current Sensing Unit

Quantity: 2

Optical inputs:

From other Current Sensing Unit

Quantity: 1

Indications:

Signal to Arc Monitor/Current Sensing Unit

Green LED lit up at load current < set overcurrent level

Pre-warning Yellow LED lit up at load current < approx. 70% of set overcurrent level

Test position Red LED

Control devices/settings:

(on the p.c.b.)

Change-over switch

Test position On/Off
Optical input is used or not On/Off

Trimming potentiometers

Setting of overcurrent level 0.5 – 3.5 x rated current
Simulation of overcurrent level in test position -

Supply voltage

Permitted variation See ordering table
+/- 20 % at DC
+/- 10 % at 110-127 V AC
+10 % -15 % at 230 V AC

Power consumption

1 W at 24 V
11 W at 220 V

Permissible ambient temperature -25...+55 °C

Operating times

From overcurrent occurring to actuating optical outputs:
At currents ≥ 2 x set overcurrent level

| | |
|-----------------|--------|
| 3-phase supply. | < 2 ms |
| 1-phase supply. | < 8 ms |

Current conditions from optical input to optical outputs < 0.3 ms

Degree of protection

IP 54

Arc Guard System TVOC

Dimension drawings

Arc Monitor Current Sensing Unit

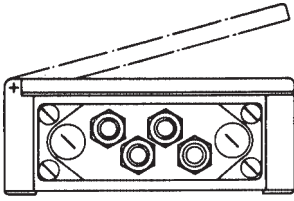

A flange with 6 tapped holes (size 18.6 mm) 4 cable glands (sealing diameter 5.5-8.5 mm) and 2 plastic blank plugs are supplied.

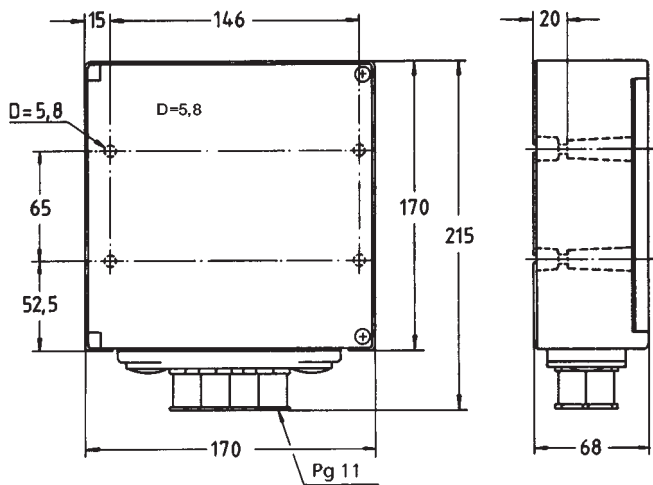

Detector with optical cable

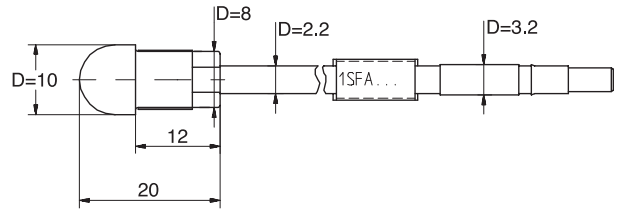

Detector and optical fibre cable

Permissible ambient temperature

| | |
|------------|--------------|
| Continuous | -25...+70 °C |
| Short-time | -25...+85 °C |

Smallest bending radius of optical cable:

| | |
|--------------------|-------|
| after installation | 45 mm |
| upon handling | 10 mm |

Terminals

| | Terminal | Cross section of connectible cables mm ² |
|----------------------|----------------|---|
| Arc Monitor | 13,14, 25...30 | 4 |
| | 20...23 | 2.5 |
| Current Sensing Unit | 1...6 | 4 |
| | 10...14 | 2.5 |

Mounting bracket

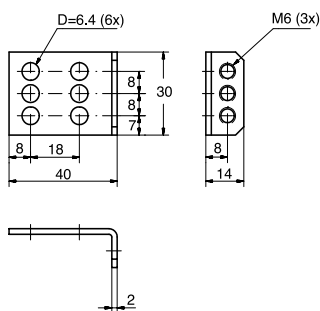

Mounting kit

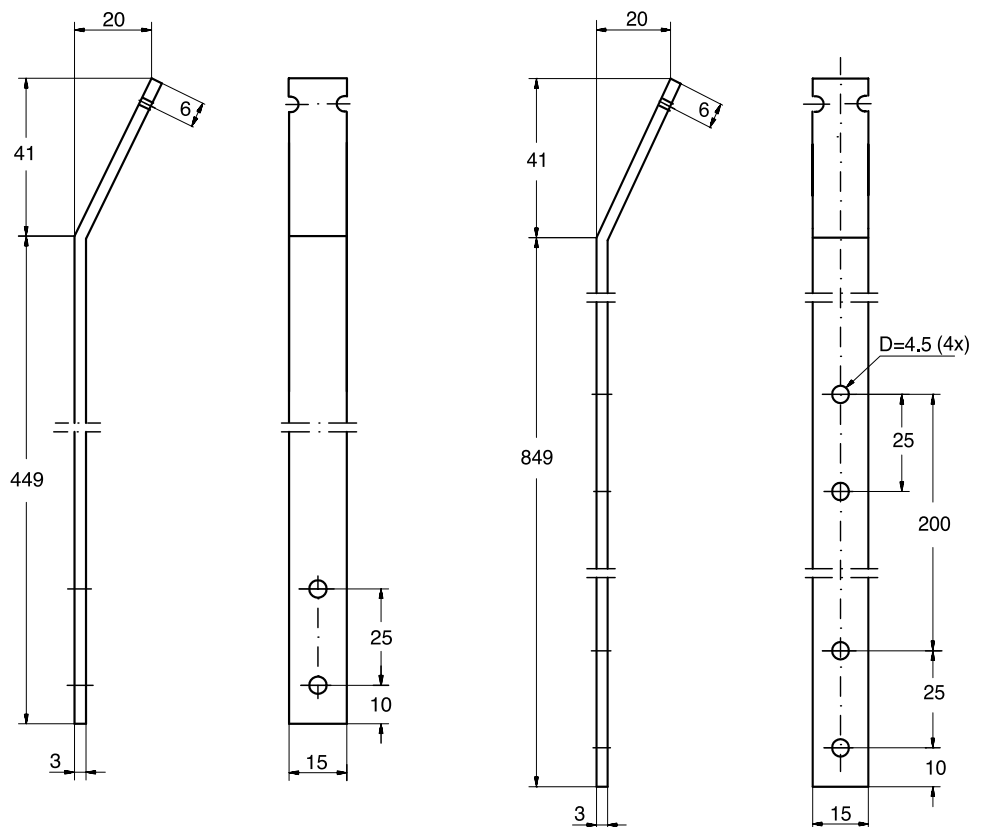

Arc Guard System TVOC

Application diagrams

Current Sensing Unit

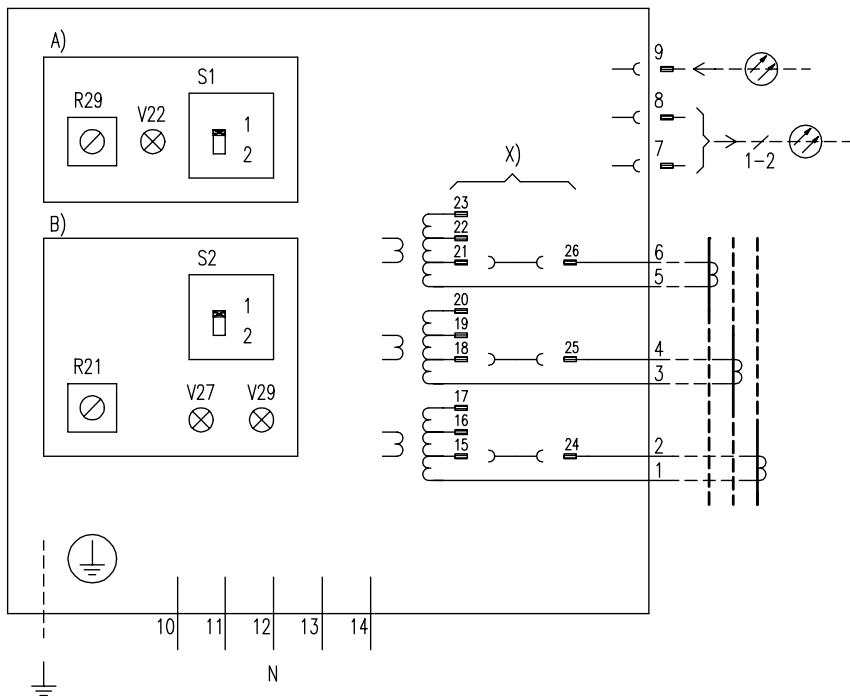

Power supply terminals

| | |
|------------------|-------------------------------|
| 10 and 12 | 24 V DC |
| 11 and 12 | 60 V DC |
| 11 and 12 | 48 V DC Interconnection 11-13 |
| 13 and 12 | 110 V-125 V AC/DC |
| 14 and 12 | 220 V DC, 230 V AC |

A) Testing facilities:

| | |
|-----|--|
| R29 | Simulating a test current |
| S1 | 1 = Test position 2 = Operation position |
| V22 | Red ON = S1 in test position Red OFF = S1 in operation position |

B) Setting facilities:

| | |
|-----|---|
| R21 | Overcurrent setting |
| S2 | 1 = Input 9 not used 2 = Input 9 used |
| V27 | Yellow ON = Load current less than 70% of set overcurrent level Yellow OFF = Load current more than 70% of overcurrent level |
| V29 | Green ON = Load current less than set overcurrent level Green OFF = Load current more than set overcurrent level |

X) Current range bridge connections:

| | |
|-----|---------------------------------|
| 1A: | 24-17, 25-20, 26-23 |
| 2A: | 24-16, 25-19, 26-22 |
| 5A: | 24-15, 25-18, 26-21 On delivery |

Terminals

| | |
|-------|--|
| 1...6 | Current transformer terminals |
| 7...8 | Output current signal to another Current Sensing Unit or Arc Monitor |
| 9 | Input current signal from another Current Sensing Unit |

Arc Guard System with two separated circuit-breakers

(Suitable for Order Code 1SFA 663 001 R1001, 1SFA 663 001 R1002)

Several Current Sensing Units

The Arc Monitor can be linked with several Current Sensing Units by connecting the Current Sensing Units in series.

Parallel connection of Arc Monitors

In installations with more than one Arc Monitor. Current sensing function is transmitted to next Arc Monitor via fibre cable (4).

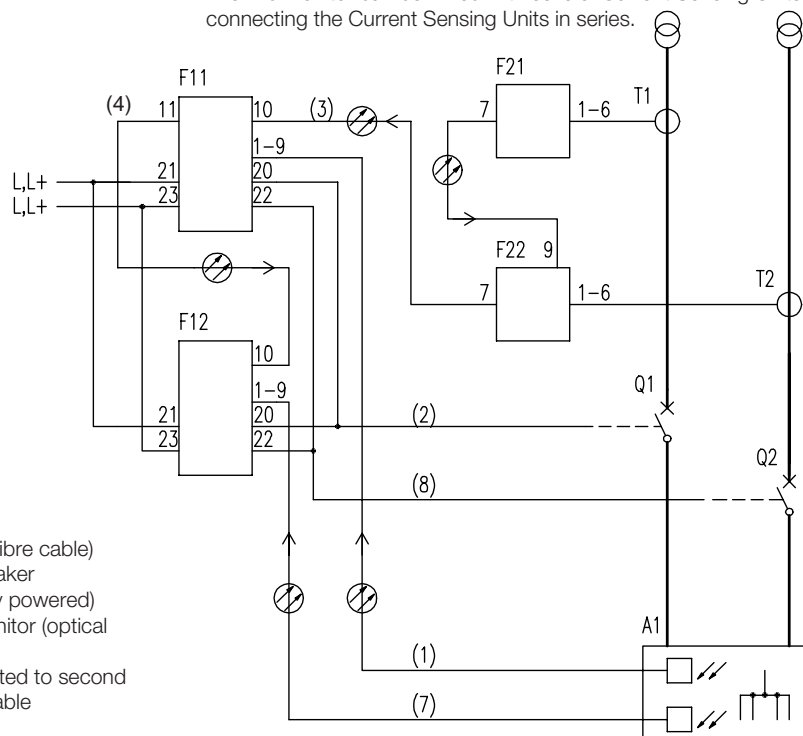

| | |
|----------|---|
| A1 | Switchgear or similar |
| F11, F12 | Arc Monitor |
| F21, F22 | Current Sensing Unit |
| Q1, Q2 | Circuit-breaker |
| T1, T2 | Current transformers |
| (1), (7) | Detector cables (optical fibre cable) |
| (2), (8) | Trip circuit for circuit-breaker (electric cable, separately powered) |
| (3) | Current signal to Arc Monitor (optical fibre cable) |
| (4) | Current signal is transmitted to second Arc Monitor via optical cable |

Arc Guard System TVOC

Application diagrams

Arc Guard System with current measuring in five incoming feeders (Suitable for Order Code 1SFA 663 001 R1001, 1SFA 663 001 R1002)

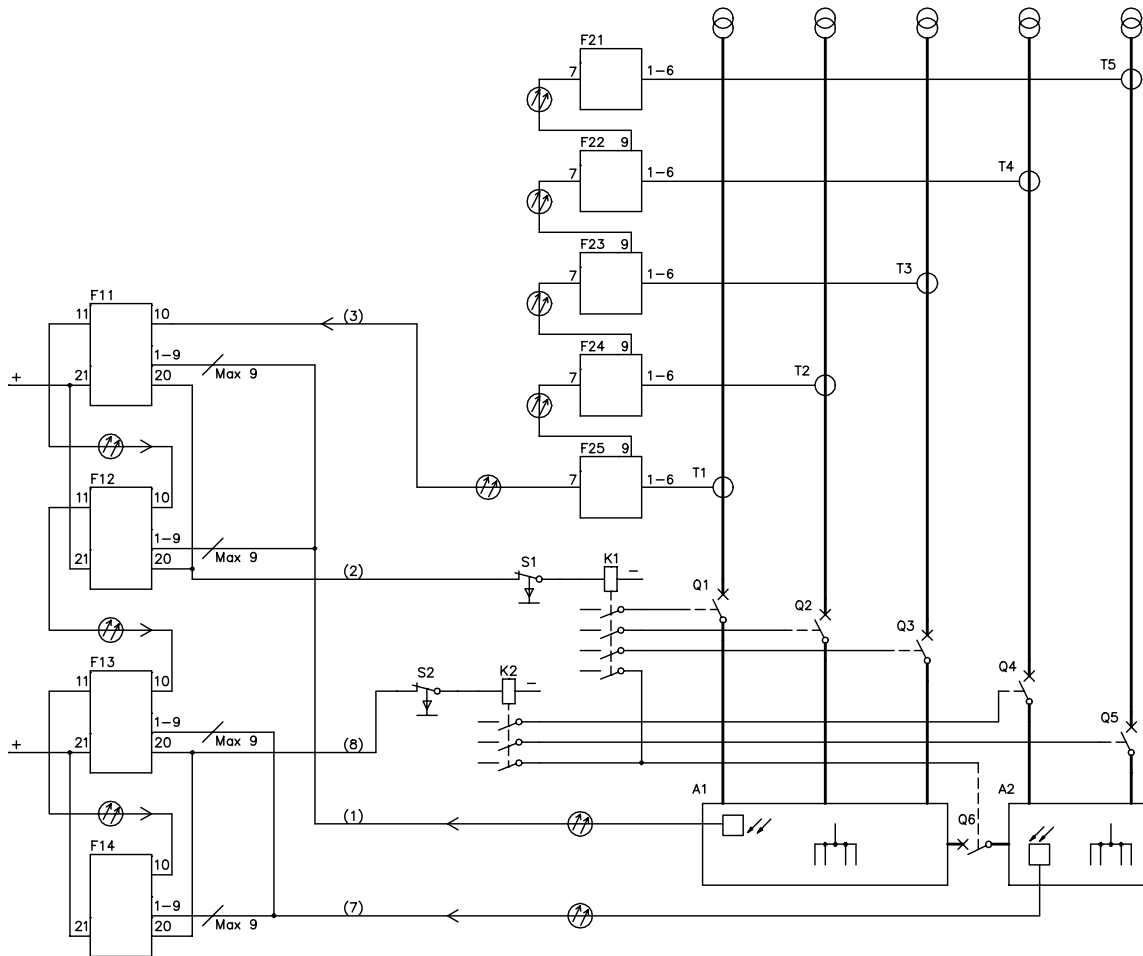

| | | | |
|-----------|-----------------------|----------|--|
| A1, A2 | Switchgear or similar | (1), (7) | Detector cables (optical fibre) |
| F11...F15 | Arc Monitor | (2), (8) | Trip circuit for circuit-breaker (electric cable, separately powered) |
| F21...F25 | Current Sensing Unit | | |
| K1, K2 | Fast tripping relay | (3) | Current signal to Arc Monitor (optical fibre cable) |
| T1...T5 | Current transformers | | |
| Q1...Q5 | Circuit-breaker | | |
| Q6 | Bus coupler | | |



ABB Automation Technology Products AB/Control
SE-721 61 Västerås, Sweden

Catalogue 1SFC 266006-en, Edition 3, November 2003
Supersedes Catalogue 1SFC 266006-en, Edition 2,
November 2000

Telephone +46 21-32 07 00
Telefax +46 21-12 60 01